

PANEL1170-810

17" Pentium-M PANEL PC

User's Manual

Disclaimers

The information in this manual has been carefully checked and is believed to be accurate. AXIOMTEK Co., Ltd. assumes no responsibility for any infringements of patents or other rights of third parties, which may result from its use.

AXIOMTEK assumes no responsibility for any inaccuracies that may be contained in this document. AXIOMTEK makes no commitment to update or to keep current the information contained in this manual.

AXIOMTEK reserves the right to make improvements to this document and/or product at any time and without notice.

No part of this document may be reproduced, stored in a retrieval system, or transmitted, in any form or by any means, electronic, mechanical, photocopying, recording, or otherwise, without the prior written permission of AXIOMTEK Co., Ltd.

©Copyright 2005 by AXIOMTEK Co., Ltd.

All rights reserved.

April 2005, Version A1

Printed in Taiwan

Safety Approvals

- ◆ CE Marking
- ◆ FCC Class A

FCC Compliance

This equipment has been tested and complies with the limits for a Class A digital device, pursuant to Part 15 of the FCC Rules. These limits are designed to provide reasonable protection against harmful interference in a residential installation. If not installed and used in accordance with proper instructions, this equipment might generate or radiate radio frequency energy and cause harmful interference to radio communications. However, there is no guarantee that interference will not occur in a particular installation. If this equipment does cause harmful interference to radio or television reception, which can be determined by turning the equipment off and on, the user is encouraged to try to correct the interference by one or more of the following measures:

1. Reorient or relocate the receiving antenna.
2. Increase the separation between the equipment and receiver.
3. Connect the equipment into an outlet on a circuit different from that to which the receiver is connected.
4. Consult the dealer or an experienced radio/TV technician for help.

Shielded interface cables must be used in order to comply with emission limits.

Safety Precautions

Before getting started, read the following important cautions.

1. The PANEL1170-810 does not come equipped with an operating system. An operating system must be loaded first before installing any software into the computer.
2. Be sure to ground yourself to prevent static charge when installing the internal components. Use a grounding wrist strap and place all electronic components in any static-shielded devices. Most electronic components are sensitive to static electrical charge.
3. Disconnect the power cord from the PANEL1170-810 before making any installation. Be sure both the system and the external devices are turned OFF. Sudden surge of power could ruin sensitive components. Make sure the PANEL1170-810 is properly grounded.
4. The brightness of the flat panel display decreases with usage. However, hours of use vary depending on the application environment.
5. Turn OFF the system power before cleaning. Clean the system using a cloth only. Do not spray any liquid cleaner directly onto the screen. The PANEL1170-810 may come with or w/o a touchscreen. Although the touchscreen is chemical resistant, it is recommended that you spray the liquid cleaner on a cloth first before wiping the screen. In case your system comes without the touchscreen, you must follow the same procedure and not spray any cleaner on the flat panel directly.
6. Avoid using sharp objects to operate the touchscreen. Scratches on the touchscreen may cause malfunction or internal failure to the touchscreen.
7. The flat panel display is not susceptible to shock or vibration. When assembling the PANEL1170-810, make sure it is securely installed.

5. Do not open the system's back cover. If opening the cover for maintenance is a must, only a trained technician is allowed to do so. Integrated circuits on computer boards are sensitive to static electricity. To avoid damaging chips from electrostatic discharge, observe the following precautions:
 - ✓ Before handling a board or integrated circuit, touch an unpainted portion of the system unit chassis for a few seconds. This will help to discharge any static electricity on your body.
 - ✓ When handling boards and components, wear a wrist-grounding strap, available from most electronic component stores.

Trademarks Acknowledgments

AXIOMTEK is a trademark of AXIOMTEK Co., Ltd.

IBM, PC/AT, PS/2, VGA are trademarks of International Business Machines Corporation.

Intel and Pentium are trademarks of Intel Corporation.

MS-DOS, Microsoft C and QuickBASIC are trademarks of Microsoft Corporation.

VIA is a trademark of VIA Technologies, Inc.

SST is a trademark of Silicon Storage Technology, Inc.

UMC is a trademark of United Microelectronics Corporation.

Other brand names and trademarks are the properties of their respective owners.

This page does not contain any information.

Table of Contents

Chapter 1 Introduction -----	1
1.1 General Description.....	1
1.2 Specifications	2
1.3 Dimensions	5
1.4 Front View and I/O Outlets	6
1.4.1 Front View.....	6
1.4.2 I/O Outlet.....	7
1.5 Package list.....	8
Chapter 2 Hardware Installatiion -----	9
2.1 CPU and DRAM Installation.....	9
2.2 HDD Installation.....	11
2.3 CD-ROM Installation	13
2.4 Add-on Card Installation	15
2.5 3 x Serial Ports	16
2.6 Parallel Port	16
2.7 VGA	16
2.8 Ethernet.....	17
2.9 Mountings: Panel/Wall/Desktop/VESA/Rack... ..	18
2.9.1 VESA-ARM	18
2.9.2 Wall Mount.....	19
2.9.3 Desktop Kit Assembly.....	21
2.9.4 Panel-mount Kit Assembly	23
2.9.5 Rack mounting Assembly	24
Chapter 3 Driver Installation -----	25
3.1 System	25
3.2 Touch Screen	26
3.2.1 Specification	26

3.2.2	Driver Installation- Windows 98/2000/XP/CE.NET/XP-Embedded	27
3.2.3	Driver Installation- DOS.....	29
3.2.4	Driver Installation- Linux.....	31
3.3	Dual LAN	33
Chapter 4 Embedded O.S. Installation -----		35
4.1	Windows XP Embedded.....	35
4.1.1	Penmount Touch Screen	35
4.2	Windows CE.NET 4.2	36
4.2.1	Calibration Touch Screen.....	36
Appendix A SB83810 BIOS Setup -----		37
A.1	Standard CMOS Setup Menu	37
A.2	Advanced BIOS Features.....	40
A.3	Advanced Chipset Features	45
A.4	Integrated Peripherals	47
A.5	Power Management Setup	52
A.6	PnP/PCI Configuration Setup	57
A.7	PC Health Status.....	59
A.8	Frequency/Voltage Control.....	60
A.9	Load Fail-Safe Defaults	61
A.10	Load Optimized Defaults	62
Appendix B Power Supply Specification -----		63

Chapter 1

Introduction

This chapter contains the general information and the detail specifications of the PANEL1170-810. Chapter 1 includes the following sections:

- General Description
- System Specification
- Dimensions
- Front View & I/O Outlets
- Package List

1.1 General Description

The PANEL1170-810 is an ultra slim Panel PC which equipped with superior Pentium® M processor and 17" SXGA LCD display. PANEL1170-810 has friendly user interface design of using front access USB, may let the customers easily connect keyboard/mouse and USB storage device. In addition, with P-M CPU and the advanced radiation design, PANEL1170-810 has better stability and the ultra slim overhead construction. The Back Door design also makes PANEL1170-810 to be extremely easy to maintain.

Front Access USB Ports & OSD

To enhance the system for easy maintenance and upgrade, the two front USB ports have been build-in to the front panel. By connecting the USB storage devices to the front USB ports, users can upgrade or maintain the software without dismount the panel PC from the rack. The OSD control keypads allows the users to tune the display brightness and position at front panel which ensures the users always get the best display condition for any specific application.

Most Reliable and Stable Design-Intel® Pentium® M Processor

The Pentium®-M processor delivers outstanding computing performance and low-power enhancements. Therefore, with the remarkable radiation design and using P-M CPU, PANEL1170-810 is

a high stability and high reliable Panel PC. At the same time, with the Ultra Slim case design, customers can easily install PANEL1170-810 everywhere.

Easy-to-Maintenance Design: Back Door

The back panel of the PANEL1170-810 was anchored by hand-removable fasten screws. Users can install the CPU, Memory, and HDD without using screw driver to open the main cabinet. This modular design helps to minimize system down-time for maintenance. The two front accessible USB ports also enable the easy connection of input devices such as Keyboard or Mouse. By connecting to USB FDD, CD-ROM, or Memory Stick, users can update the newest software to the system or download the system information to memory devices.

1.2 Specifications

Main CPU board

- **CPU:** Intel® Pentium® M up 1.8GHz
- **System Chipset:** Intel® 855GME/6300ESB
- **BIOS:** Phoenix-Award BIOS, Y2K compliant 4Mbit Flash, DMI, Plug and Play SmartView for multiple LCD type selection, display mode option and application extension features RPL/PXE Ethernet Boot ROM
"Load Optimized Default" to backup customized Setting in the BIOS flash chip to prevent from CMOS battery fail
- **System Memory:** One 184-pin DIMM socket
200/266/333MHz ECC/non-ECC DDR
SDRAM supported Maximum SDRAM of up to 1GB
- **L2 Cache:** Integrated in CPU
- **Bus Clock:** 400 MHz
- **Watchdog Timer:** Integrate Intel® 6300ESB
Up to 300 levels as Reset feature

I/O System

■ Standard I/O:

- 3 x serial ports with power; 2 x RS-232, 1 x RS-232/422/485 jumper selectable
- 1 x parallel port, SPP/EPP/ECP
- 1 x PS/2 for Keyboard Interface
- 1 x PS/2 for Mouse Interface
- 3 x USB Ports 2.0 compliant(1 at rear; 2 at front panel)
- 1 x 15 pin(female) for VGA output

■ Ethernet:

Realtek 8100C PCI Bus 10/100M Base-T
Wake On LAN (via ATX power supply)
Equipped with RJ-45 interface
Realtek RTL8110S for 10/100/1000Base-T

■ Audio:

Realtek ALC202A AC'97 codec audio
Amplify for speaker-out with 2.5W for each channel
MIC-in, Line-in, Line-out/Speaker-out (jumper selectable)

■ Onboard IDE:

4 channels up to 6 devices (2 parallel ATA-100 and 2 serial ATA-150)
RATA-100 as PIO Mode 0-4, DMA Mode 0-2 and Ultra DMA/33/66/100

■ Onboard Serial ATA:

Independent DMA operation on two ports.
Data transfer rate up to 150 Mbyte/s
Alternate Device IDE and RAID Class Code option for support of Soft RAID.

System Specification

- **17" TFT LCD**
- **Disk drive housing:**
 - 1x Build-in Slim type FDD,
 - 1x optional slim type CD-ROM drive,
 - 1 x internal 3.5" drive (or 2X 2.5" HDD)
- **180W AC power supply**
- **Heat dispensing design**
- **One slot for PCI expansion**
- **Net weight:**
 - 13.5 Kgs
- **Dimension (main body size):**
 - 482.8 x 354.8 x 105.9 mm
- **Operating temperature:**
 - 0° to 45°C ; Relative umidity:50%
- **Relative humidity:**
 - 10% to 85% @ 40° C, on-condensing
- **Altitude:**
 - 10,000 ft. (3,000 meters)
- **Vibration (operating):**
 - 5 to 500 Hz, 1 G random
- **Shock (operating):**
 - 10 G peak acceleration (11 msec. duration)

1.3 Dimensions

The following diagrams show the dimensions and outlines of PANEL1170-810.

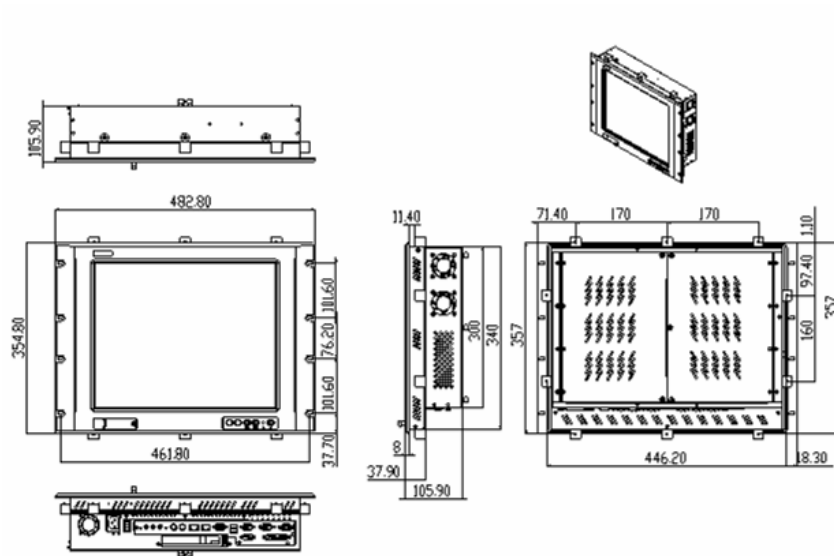

1.4 Front View and I/O Outlets

1.4.1 Front View

The figure below shows the features and controls on the PANEL1170-810 front panel.



- 1. USB
- 2. USB
- 3. SEL-
- 4. SEL+
- 5. Backlight on/off

1.4.2 I/O Outlet

The following figure shows the I/O locations of the PANEL1170-810. Most of the I/O connectors are located on the back panel of the PANEL1170-810.

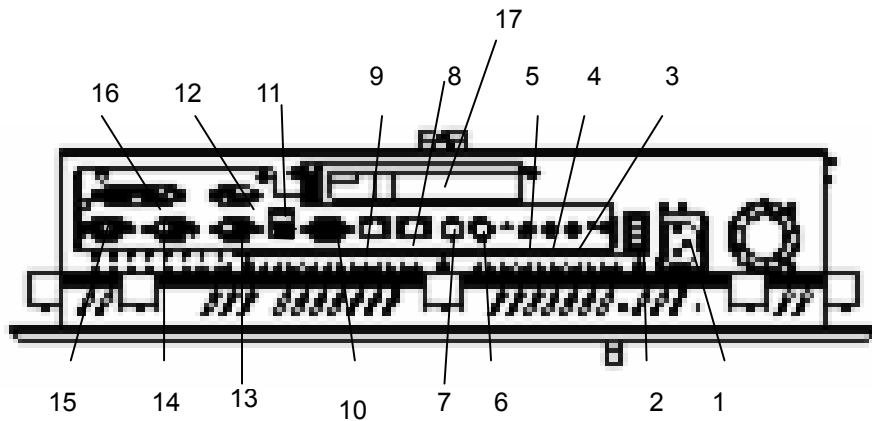

- | | |
|-------------------------|-------------------------|
| 1: AC inlet | 10: VGA |
| 2: Power Switch | 11: USB v 2.0 |
| 3: Line-in | 12: COM3 Port(for T/S) |
| 4: Mic | 13: COM1 Port |
| 5: Line-Out | 14: COM2 Port |
| 6: Mouse | 15: COM4 Port |
| 7: Keyboard | 16: PRN (Parallel Port) |
| 8: 10/100 Ethernet | 17: PCMCIA Slot |
| 9: 10/100/1000 Ethernet | |

1.5 Package list

When you receive the PANEL1170-810 there are following items in the package. If you can not find it, please contact AXIOMTEK distributors.

1. P1170-810 x 1
2. CPU cooler x 1
3. AC power cord x 1 (U.S standard)
4. Panel mount kit x 10
5. Desktop kit x 2
6. VESA ARM kit x 1
7. Wall mount kit x 1
8. CD driver x1

Chapter 2

Hardware Installation

The PANEL1170-810 provides lots of flexible ways for you to select different configuration such as CPU, CD-ROM and more. The chapter will show you how to install the hardware. It includes:

2.1 CPU and DRAM Installation

The standard PANEL1170-810 system was designed Pentium M level CPUs. The build-in CPU board provides one 184-pin DDR DIMM socket that supports system memory up to 1GB. And, there is one mini-PCI type-III Socket.

When upgrading the CPU, DRAM, or Mini-PCI, refer to the following instructions and illustration:

1. Unscrew five screws in the back door.



2. Install the CPU, DDR DRAM and Mini-PCI card in the P-1170-810.

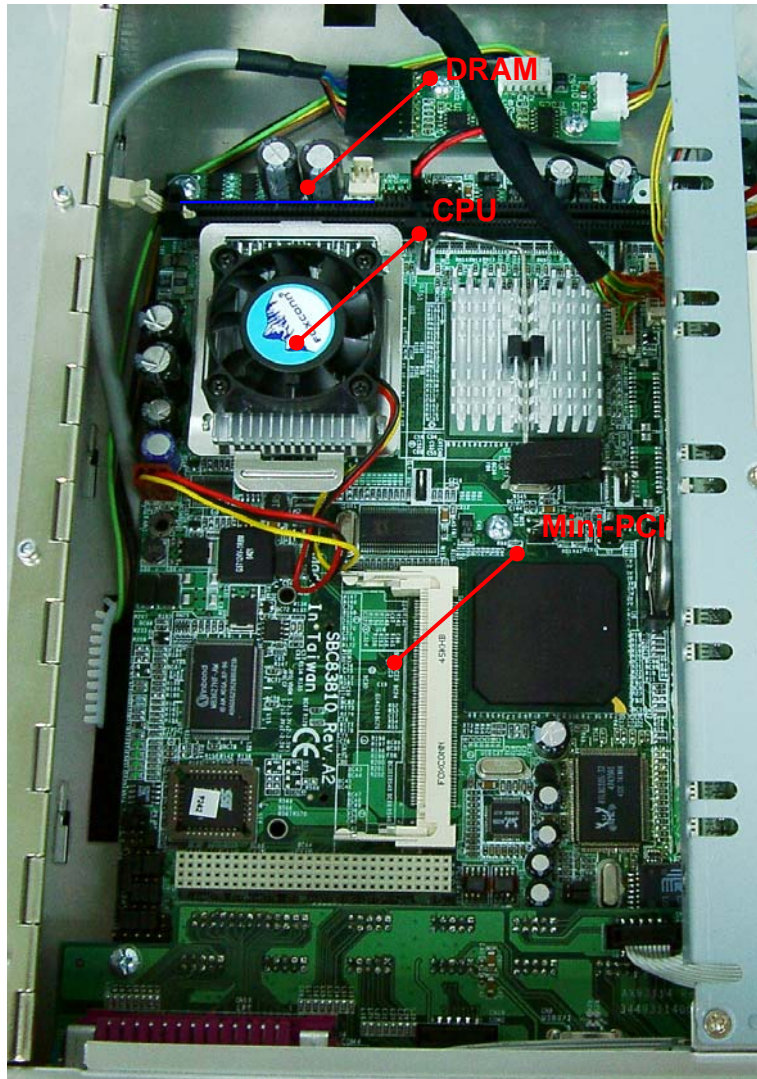

2.2 HDD Installation

The PANEL1170-810 offers a convenient drive bay module for users to install HDD. The PANEL1170-810 offers one 3.5" HDD drive for users to install. If you want to install two 2.5" HDDs, the PANEL1170-810 also provides the 3.5" to 2.5" drive holder to meet your requirement. Please follow the steps:

1. Open the back door.
2. Unscrew 3 screws and remove the riser card bracket kit.

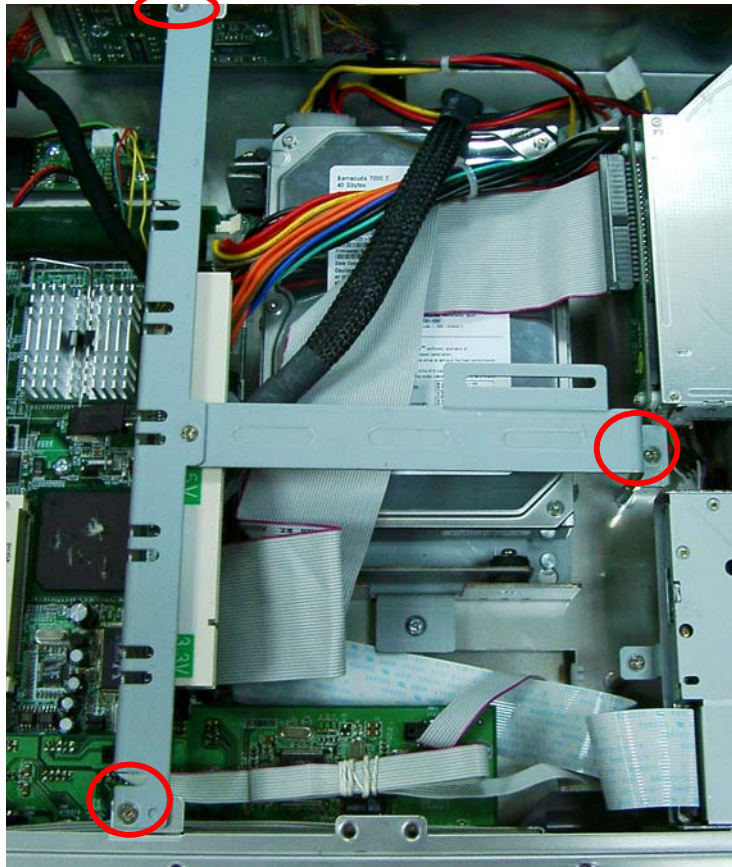

3. Unscrew 1 screw from the HDD drive bracket, and push the HDD bracket kit.

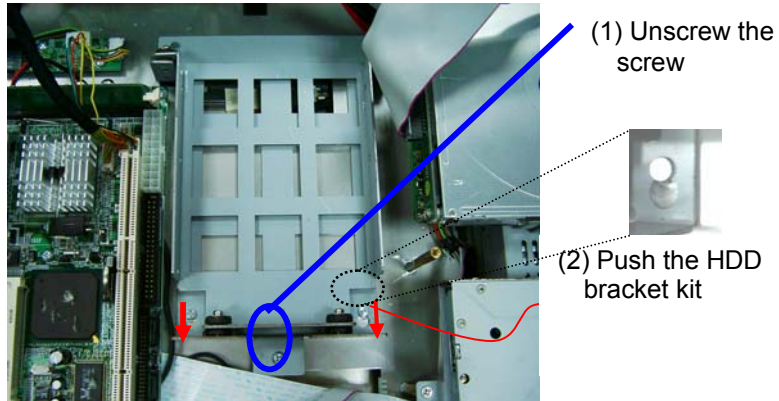

4. Set the 3.5" HDD (or 2.5" HDD) in the HDD bracket kit and fix it by 4 screws around the bracket kit.



5. Installation complete.

2.3 CD-ROM Installation

The PANEL1170-810 offers a convenient drive bay module for users to install CD-ROM. When installing the CD-ROM, refer to the following instructions and illustration:

1. Open the back door.
2. Unscrew 3 screws and remove the Riser card bracket kit.

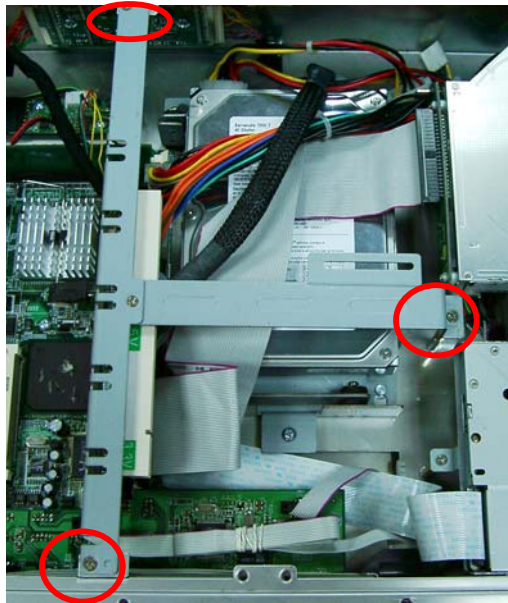

3. Secure 2 screws to fix the CD-ROM PCB board.



4. Put the CD-ROM in the drive bracket and fix it by 6 screws.

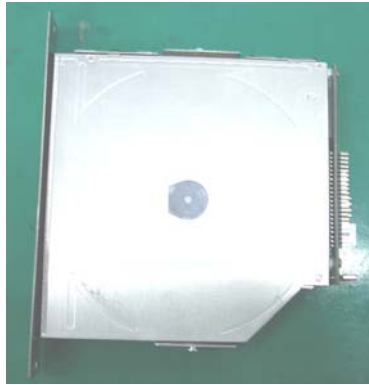
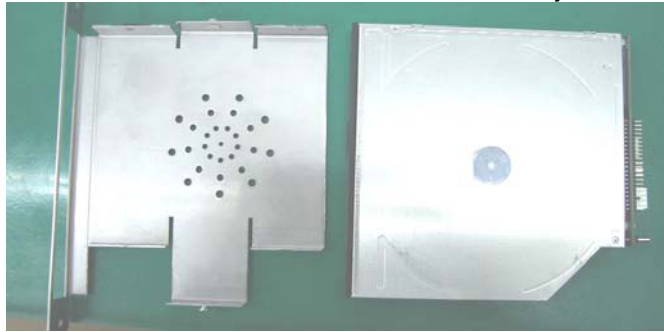

5. Fix CD-ROM drive bracket by two screws at the side of the PANEL1170-810.

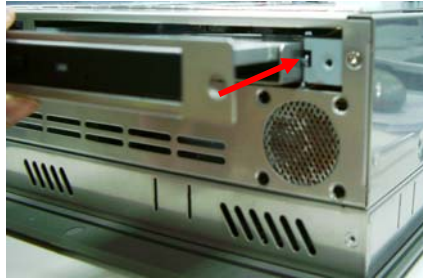

2.4 Add-on Card Installation

The PANEL1170-810 provides a riser card for PCI slots expansion. The riser card assembly can accommodate both half-size expansion cards. To install the riser card, refer to the following figure and instructions below:

When upgrading the add-on card, refer to the following instructions and illustration:

1. Open the back door of the system.
2. Unscrew 2 screws.



3. Plug the add-on card into the slot.

2.5 3 x Serial Ports

The PANEL1170-810 provides three onboard serial ports installed on the back bottom side of the chassis. For systems, COM1 and COM2 are RS-232 and COM4 is RS-232/422/485. Each serial port is with +5V/+12V power capabilities on both Pin 1 and Pin 8, ready to accommodate a wide array of serial devices, such as fax modem, scanner, serial mouse and touch screen...etc.

COM1 to COM4 are all D-SUB 9-pin connectors. To connect any serial devices, just plug in the device connector to the 9-pin D-SUB. In terms of transmission distance, the RS-422/485 will perform better than RS-232. In this case, COM4 is suggested to be set to RS-422/485 and the related jumpers have to be set correctly first (see the system board User's Manual). The RS-422/485 pin assignment is listed as follows;

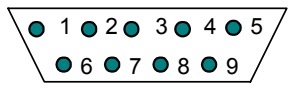

Pin #	Signal Name	
	R2-422	RS-485
1	TX-	DATA-
2	No connector	No connector
3	TX+	DATA+
4	No connector	No connector
5	RX+	No connector
6	No connector	No connector
7	RX-	No connector
8	No connector	No connector
9	GND	GND
10	No connector	No connector

2.6 Parallel Port

The printer interface is a 25-pin D-SUB connector. To connect any parallel device, just plug in the device connector to the 25-pin D-SUB.

2.7 VGA

The PANEL1170-810 has an analog RGB interface connector. It is able to connect to an expansion CRT monitor, and the system can display on both the flat panel and the CRT simultaneously.

2.8 Ethernet

The PANEL1170-810 provides an NE2000 compatible Ethernet (RJ-45) interface. For network connection, just plug in one cable end of the PANEL1170-810 10/100/1000-Base-T Hub into the standard RJ-45 connector. The pin assignment of the RJ-45 is listed below;

RJ-45 Connector Pin Assignment

Pin	Signal
1	TX+ (Data transmission positive)
2	TX- (Data transmission negative)
3	Rx+ (Data reception positive)
4	RJ45 termination
5	RJ45 termination
6	Rx- (Data reception negative)
7	RJ45 termination
8	RJ45 termination

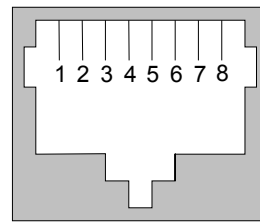

RJ-45

2.9 Mountings: Panel/Wall/Desktop/VESA/Rack

There are 5 application options for the PANEL1170-810, Panel/Wall/Desktop/VESA/Rack mountings.

2.9.1 VESA-ARM

The PANEL1170-810 provides two ways for VESA mount: 75x75 mm and 100x100 mm. Screw four screws to fix the kit (included in the package) in the back chassis.



2.9.2 Wall Mount

The PANEL1170-810 is designed for Wall mount application. To mount the PANEL1170-810, the standard set of mounting kit (included in the system packaging) is needed. Please refer to the following figure.

1. Fix VESA bracket kit in back of chassis by 4 screws.



2. Fix the Wall mount bracket kit in back of the VESA bracket kit by 4 screws.

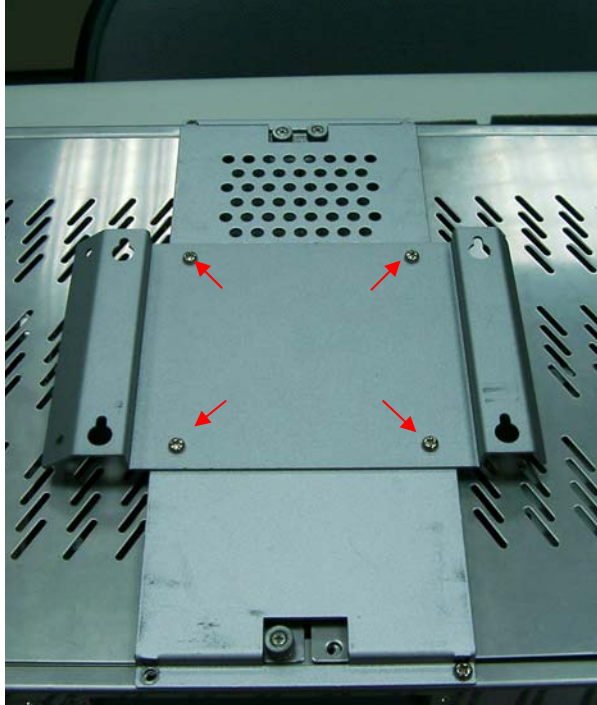

2.9.3 Desktop Kit Assembly

The PANEL1170-810 is designed for desktop application. The standard set of desktop kit is included in the system packaging. Please refer to the following figure.

1. Fix VESA bracket kit in back of chassis by 4 screws.
2. Fix the Wall mount bracket kit in back of the VESA bracket kit.

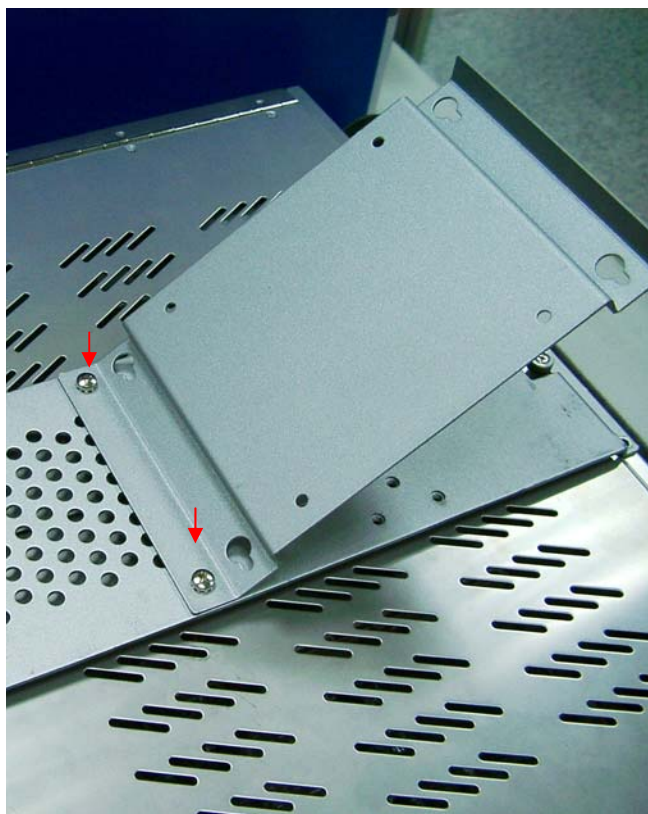

3. Fix two holders by 2 screws.



4. Complete.



2.9.4 Panel-mount Kit Assembly

The PANEL1170-810 is designed for panel mount application. To mount the PANEL1170-810, the standard set of mounting kit (included in the system packaging) is needed.



2.9.5 Rack mounting Assembly

The PANEL1170-810 is designed for rack mounting application. Remove plugs from front panel. Then, user could mount PANEL1170-810 at their rack.

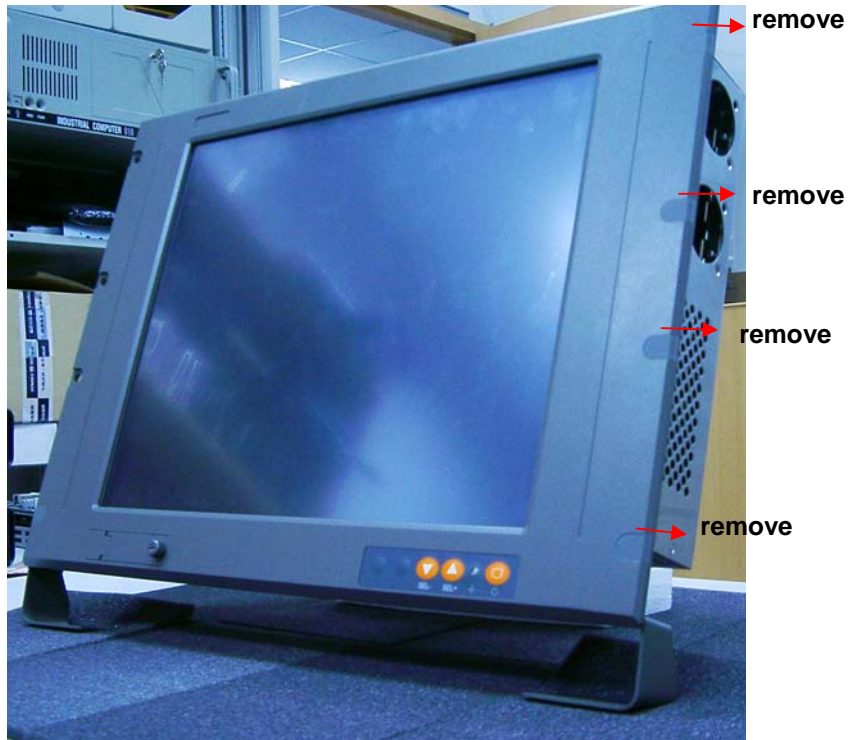

Chapter 3

Driver Installation

3.1 System

PANEL1170-810 could support with Windows 95, Windows 98 or Windows 2000/XP. To facilitate installation system driver, you should read the instructions in this chapter carefully before you attempt installation.

1. Insert Driver CD and select the \P1170-810\Driver\..



2. Select all files and follow the install procedure and press OK.

3.2 Touch Screen

3.2.1 Specification

Touch Screen:	For 8-wire analog resistive type
Touch Screen Controller:	DMC9000
Communications:	RS-232
Baud Rate:	19200 baud rate fixed
Resolution:	1024 x 1024 (10-bit A/D converter inside)
Power Input:	5V to 12V DC
Power Consumption:	12V: 27mA+ i where (i = v/touch screen sheet R) 5V: 23mA+ i where (i = v/touch screen sheet R)
Board Size:	6.0 x 2.0 cm
Portrait:	Support 90° to 270° screen rotation
Static Protection:	ESD device option
Others:	Touch activate indication LED on board

3.2.2 Driver Installation- Windows 98/2000/XP/CE.NET/XP-Embedded

The touch screen of PANEL1170-810 provides a driver for use with Windows 95, Windows 98 or Windows 2000/XP. To facilitate installation of the touch screen driver, you should read the instructions in this chapter carefully before you attempt installation.

1. Insert Driver CD and select the “\P1170-810\Driver\Touch screen\Windows 9x or 2k or XP or CE\Setup.exe”

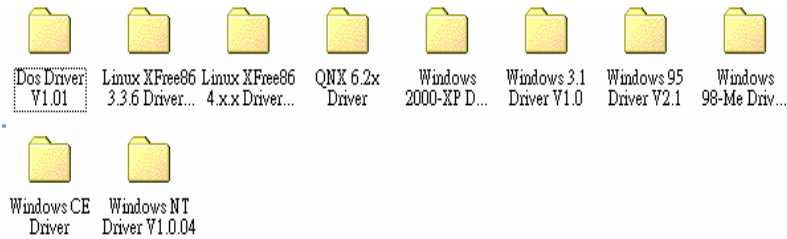

2. Follow the install procedure and press OK.
3. Click Start menu and select “PenMount Utilities”. You can see PenMount Control Panel

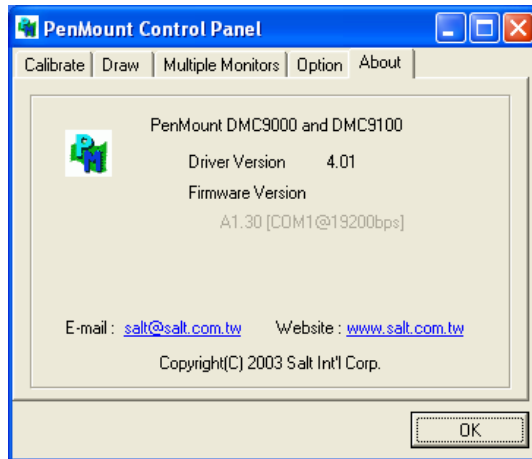

4. Select the “Standard Calibrate” tab

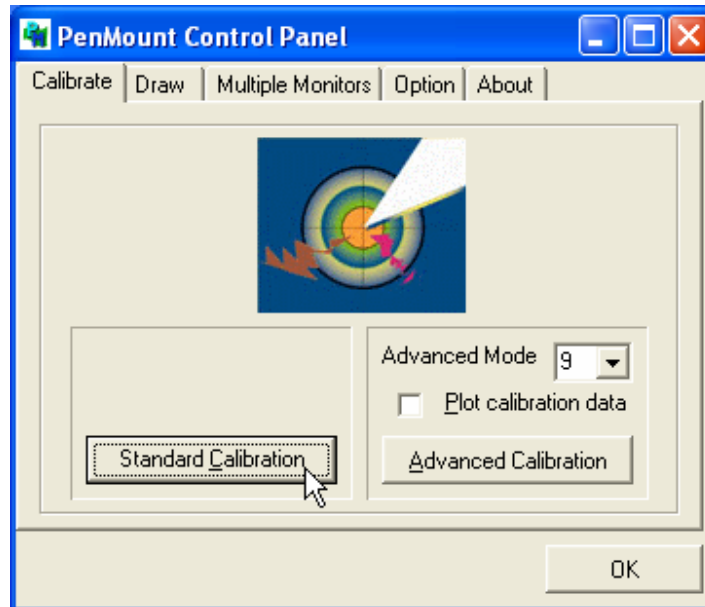

5. Calibration:

To adjust the display with touch panel, click “Calibration” and follow the calibrate point to do calibration; there are five points on screen for calibration.

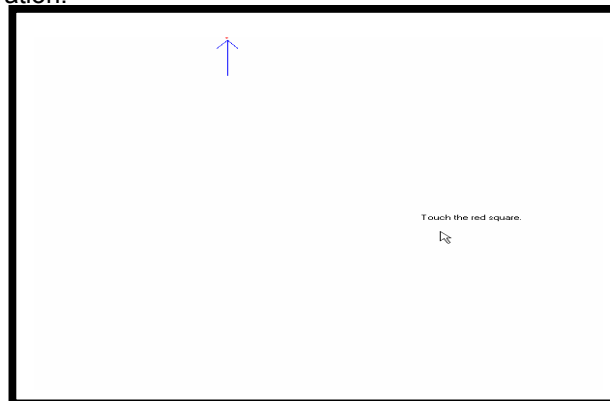

6. Press OK.

3.2.3 Driver Installation- DOS

Using "INSTALL.EXE" utility to install PenMount software driver.

1. Insert Driver CD and select the \P1170-810\Driver\Touch screen\DOS\ Install.exe
2. Press ENTER key to install the drivers to drive C or use keyboard to key-in the hard disc drive that you plan to install the driver.
3. The driver will ask "Do you want to modify your Autoexec.bat to initialize PenMount? (Y/N)" Suggest you choose "YES" for generating the initialization instructions in AUTOEXEC.BAT files. Then follow up the instructions to complete the installation.

Identify the communication port and IRQ number

1. For the first time installation, or changing PenMount Touch Screen's COM port, use PMDETECT (e.g. C:\PENMOUNT\PMDETECT) to check the COM port and IRQ number. PMDETECT will save the correct data to PMOUSE.CFG file for further use.

The driver detects your communication COM port and IRQ number from COM1 IRQ4, COM2 IRQ3, COM3.... to COM4 IRQ15. PenMount driver can find the COM port and IRQ number automatically. The screen will then show:

PenMount is initialized successfully!!!

Create file "pmouse.cfg". Success.

PenMount internal settings:

Comm. Port: COM<n> IRQ<n>

.....

1. PMDETECT program is able to skip the IRQ number detecting if you Touchscreen Driver Installation **13** do not need to detect the specified IRQ number. For example, you do not need to detect IRQ5, and the command is:

C:\PENMOUNT\PMDETECT -N5

If you do not need to detect IRQ5 and IRQ9, the command is:

C:\PENMOUNT\PMDETECT -N5 -N9

Do Calibration

1. To adjust the touch screen mapping properly to display screen, use PM.BAT (C:\PENMOUNT\PM) to do calibration. Choose "1" DO CALIBRATION (adjust screen mapping).
2. The message on screen asks you to select video mode number. Select

by keyboard to start the calibration, touch the upper-center point, then right-center point, bottom-center point and left-center point in sequence. After calibration, the data is shown in the screen, press any key to continue the progress.

3. After the calibration, suggest you to test touch screen and display mapped results by choose "3" DRAWING TEST under PM.BAT

Initializing the PenMount driver

If you don't have the initialization commands in AUTOEXEC.BAT, initialize PenMount (C:\PENMOUNT\PMINIT) controller before you use the PenMount Touch Screen. The display will show the initialization message:

PenMount V7.06 Copyright(c) SALT International Corp.

Test:COM<n> IRQ<n> (<n> is the number after PMDETECT done)

PenMount communication settings: COM<N> IRQ<n> Baud Rate:

<xxxx>

.....

Demonstration

To demonstrate or test touch screen operation, selecting "3" DRAWING

TEST in PM.BAT file of Utility Directory. Drawing on screen. The other demonstration program called "ICECREAM.EXE" in the "PENMOUNT" directory can also be applied.

3.2.4 Driver Installation- Linux

Install PenMount driver

1. Insert Driver CD and select the “\P1170-810\Driver\Touch\Linux XFree86 4.x.x Driver V2.1\Driver\penmount_drv.o”
2. Follow the install procedure and press OK.
3. Please reboot system.
4. Click Start menu and select “PenMount Utilities”. You can see PenMount Control Panel

Advance Setup

1. Before install the Touch Screen Driver, please open the file in Linux

File /etc/rc.local

```
#!/bin/sh
# file /etc/rc.local
# This script will be executed «after» all the other init scripts.
# You can put your own initialization stuff in here if you don't
# want to do the full Sys V style init stuff.

touch /var/lock/subsys/local

# Add setserial command for Com3 and Com4 setting
setserial /dev/ttyS2 port 0x3e8 irq 10
setserial /dev/ttyS3 port 0x2e8 irq 11
# end-
```

2. Key-in the following words.

Setserial /dev/ttyS2 port 0x3e8 irq 10 (set COM3 as touch screen port)

```
#!/bin/sh
# file /etc/rc.local
# This script will be executed *after* all the other init scripts.
# You can put your own initialization stuff in here if you don't
# want to do the full Sys V style init stuff.

touch /var/lock/subsys/local

# Add setserial command for Com3 and Com4 setting
setserial /dev/ttyS2 port 0x3e8 irq 10
# end-
```

3. Save and exit.
4. Please reboot.
5. After reset system, Insert Driver CD.

Do Calibration

1. Insert Driver CD and select the “\P1170-810\Driver\Touch\Linux XFree86 4.x.x Driver V2.1\Calibration\pencil-2.00”
2. Follow the install procedure and press OK.
3. Please reboot system.

3.3 Dual LAN

The Dual LAN of PANEL1170-810 provides a driver for use with Windows 95, Windows 98 or Windows 2000/XP. To facilitate installation of the Dual LAN driver, you should read the instructions in this chapter carefully before you attempt installation.

1. Insert Driver CD and select the “\P1170-810\Driver\ Dual LAN\Win9x_2000_XP(V1.30.611)\Setup.exe”

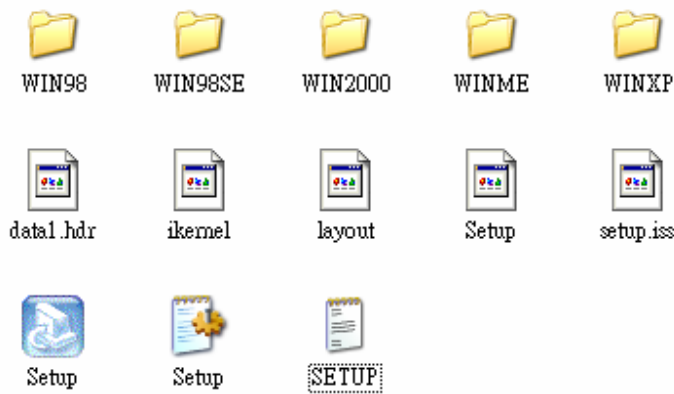

2. Follow the install procedure and press OK.

This page does not contain any information.

Chapter 4

Embedded O.S. Installation

4.1 Windows XP Embedded

Supported devices are as follows:

Onboard Multi I/O

- Floppy drive
- Parallel port
- 16C550 UARTs compatible serial port
- IrDA for wireless communication

Onboard IDE

- IDE HDD
- IDE CDROM

USB

PS2 Keyboard and mouse

CRT/LCD display

Dual LAN

Giga LAN

Compact flash

Onboard audio

Touch screen

4.1.1 Penmount Touch Screen

P1170-810 has Penmount touch screen on COM3, which is disabled by default.

Before you can use and calibrate it, you should :

1. Set up Penmount touch device driver by executing c:\Program Files\PenMount\setup.exe. When installation is finished, an icon "PM" appears on the Taskbar.
2. Calibrate Penmount touch by clicking on "PM" icon and doing calibration

3. Restart computer.

4.2 Windows CE.NET 4.2

Supported devices are as follows:

Onboard Multi I/O

- Floppy drive
- Parallel port
- 16C550 UARTs compatible serial port
- IrDA for wireless communication

Onboard IDE

- IDE HDD
- IDE CDROM

USB

PS2 Keyboard and mouse

CRT/LCD display

Compact flash

Onboard audio

Touch screen

Note: P1170-810 does not support Ethernet.

4.2.1 Calibration Touch Screen

In this image we add PenMount Touch drivers and utilities. It is customized for 1280x1024.

Calibration:

Click "**Start\Programs\PenMount
TouchPanel\Calibration**" menu item

Appendix A

SBC83810 BIOS Setup

The board used in the PANEL1170-810 is SBC83810. The different settings available in the Award BIOS that comes with the **SBC83810**. Also contained here are instructions on how to set up the BIOS configuration.

A.1 Standard CMOS Setup Menu

The items in Standard CMOS Setup Menu are divided into 10 categories. Each category includes no, one or more than one setup items. Use the arrow keys to highlight the item and then use the <PgUp> or <PgDn> keys to select the value you want in each item.

CMOS Setup Utility-Copyright © 2000-2004 Award Software
Standard CMOS Features

Date (mm:dd:yy)	Thu, Jan 10 2002	Item Help
Time (hh:mm:ss)	2 : 31 : 24	Menu Level ►
► IDE Primary Master		Change the Day, month, Year and Century
► IDE Primary Slave		
► IDE Secondary Master		
► IDE Secondary Slave		
Drive A	1.44M, 3.5 in.	
Drive B	None	
Video	EGA/VGA	
Halt On	All, But Keyboard	
↑↓→← : Move Enter: Select +/-/PU/PD: Value F10: Save ESC: Exit F1: General Help F5: Previous Values F6: Fail-Safe Defaults F7: Optimized Defaults		

Date

The date format is <day>, <date> <month> <year>. Press <F3> to show the calendar.

day	The day of week, from Sun to Sat, determined by the BIOS, is read only
date	The date, from 1 to 31 (or the maximum allowed in the month), can key in the numerical / function key
month	The month, Jan through Dec.
year	The year, depends on the year of BIOS

Time

The time format is <hour> <minute> <second> accepting either functions key or numerical key. The time is calculated based on the 24-hour military-time clock. For example, 1 p.m. is 13:00:00.

Primary Master/Primary Slave/Secondary Master/Secondary Slave

The categories identify the types of one channel that have been installed in the computer. There are 45 predefined types and 2 users definable types are for Enhanced IDE BIOS. Type 1 to Type 45 is predefined. Type User is user-definable.

Press <PgUp>/<+> or <PgDn>/<-> to select a numbered hard disk type or type the number and press <Enter>. Note that the specifications of your drive must match with the drive table. The hard disk will not work properly if you enter improper information within this category. If your hard disk drive type does not match or is not listed, you can use Type User to define your own drive type manually.

If you select Type User, related information is asked to be entered to the following items. Enter the information directly from the keyboard and press <Enter>. This information should be provided in the documentation from your hard disk vendor or the system manufacturer.

If the controller of HDD interface is ESDI, select "Type 1".

If the controller of HDD interface is SCSI, select "None".

If the controller of HDD interface is CD-ROM, select "None".

CYLS.	number of cylinders	LANDZONE	landing zone
HEADS	number of heads	SECTORS	number of sectors
PRECOMP	write precom	MODE	HDD access mode

If there is no hard disk drive installed, select NONE and press <Enter>.

Drive A type/Drive B type

The category identifies the types of floppy disk drive A or drive B installed in the computer.

None	No floppy drive installed
360K, 5.25 in	5.25 inch PC-type standard drive; 360Kb capacity
1.2M, 5.25 in	5.25 inch AT-type high-density drive; 1.2MB capacity
720K, 3.5 in	3.5 inch double-sided drive; 720Kb capacity
1.44M, 3.5 in	3.5 inch double-sided drive; 1.44MB capacity
2.88M, 3.5 in	3.5 inch double-sided drive; 2.88MB capacity

Halt On

This field determines whether the system will halt if an error is detected during power up.

No errors	The system boot will halt on any error detected. (default)
All errors	Whenever the BIOS detect a non-fatal error, the system will stop and you will be prompted.
All, But Keyboard	The system boot will not stop for a keyboard error; it will stop for all other errors.
All, But Diskette	The system boot will not stop for a disk error; it will stop for all other errors.
All, But Disk/Key	The system boot will not stop for a keyboard or disk error; it will stop for all other errors.

A.2 Advanced BIOS Features

This section allows you to configure and improve your system and allows you to set up some system features according to your preference.

**CMOS Setup Utility-Copyright © 2000-2004 Award Software
Advanced BIOS Features**

CPU Feature	Press Enter	Item Help
Hard Disk Boot Priority	Press Enter	
Virus Warning	Disabled	Menu Level ►
CPU L1 & L2 Cache	Enabled	
CPU L2 Cache	Enabled	
Quick Power On Self Test	Enabled	
First Boot Device	HDD-0	
Second Boot Device	Floppy	
Third Boot Device	SCSI	
Boot Other Device	Enabled	
Swap Floppy Drive	Disabled	
Boot Up Floppy Seek	Enabled	
Boot Up NumLock Status	On	
Gate A20 Option	Fast	
Typematic Rate Setting	Disabled	
Typematic Rate (Chars/Sec)	6	
Typematic Delay (Msec)	250	
Security Option	Setup	
APIC Mode	Enabled	
PS/2 Mouse Function Control	Enabled	
OS Select for DRAM >64MB	Non-OS2	
Report No FDD For WIN 95	No	
Full Screen Logo Show	Disabled	
Small Screen Show	Disabled	
Summary Screen Show	Enabled	
Display board ID	Disabled	
↑↓→← : Move Enter: Select +/-/PU/PD: Value F10: Save ESC: Exit F1: General Help F5: Previous Values F6: Fail-Safe Defaults F7: Optimized Defaults		

Hard Disk Boot Priority

This item can select boot device priority.

Virus Warning

This option flashes on the screen. During and after the system boot up, any attempt to write to the boot sector or partition table of the hard disk drive will halt the system with the following message. You can run an anti-virus program to locate the problem. The default setting is "Disabled".

! WARNING !
 Disk boot sector is to be modified
 Type "Y" to accept write or "N" to abort write
 Award Software, Inc.

Enabled	Activates automatically when the system boots up causing a warning message to appear when there is an attempt to access the boot sector or hard disk partition table.
Disabled	No warning message will appear when attempts to access the boot sector or hard disk partition table are made.

NOTE: *This function is only available with DOS and other operating systems that do not trap INT13.*

CPU L1 & L2 Cache

These two options speed up memory access. However, it depends on the CPU/chipset design. The default setting is "Enabled". CPUs with no built-in internal cache will not provide the "CPU Internal Cache" item on the menu.

Enabled	Enable cache
Disabled	Disable cache

Quick Power On Self Test

This option speeds up Power on Self Test (POST) after you turn on the system power. If set as Enabled, BIOS will shorten or skip some check items during POST. The default setting is "Enabled".

Enabled	Enable Quick POST
Disabled	Normal POST

First/Second/Third Boot Device

These items allow the selection of the 1st, 2nd, and 3rd devices that the system will search for during its boot-up sequence. The wide range of selection includes Floppy, LS120, ZIP100, HDD0~3, SCSI, and CDROM.

Boot Other Device

This item allows the user to enable/disable the boot device not listed on the First/Second/Third boot devices option above. The default setting is **Enabled**.

Swap Floppy Drive

This allows you to determine whether to enable Swap Floppy Drive or not. When enabled, the BIOS swap floppy drive assignments so that Drive A becomes Drive B, and Drive B become Drive A. By default, this field is set to *Disabled*.

Boot Up Floppy Seek

During POST, BIOS will determine the floppy disk drive type, 40 or 80 tracks, installed in the system. 360Kb type is 40 tracks while 720Kb, 1.2MB and 1.44MB are all 80 tracks. The default value is "Enabled".

Enabled	BIOS searches for floppy disk drive to determine if it is 40 or 80 tracks. Note that BIOS can not tell from 720K, 1.2M or 1.44M drives type as they are all 80 tracks.
Disabled	BIOS will not search for the type of floppy disk drive by track number. There will be no warning message displayed if the drive installed is 360K.

Boot Up NumLock Status

This option enables and disables the number lock function of the keypad. The default value is "On".

On	Keypad functions confine with numbers
Off	Keypad functions convert to special functions (i.e., left/right arrow keys)

Gate A20 Option

The default value is "Fast".

Normal	The A20 signal is controlled by keyboard controller or chipset hardware.
Fast	Default: Fast. The A20 signal is controlled by Port 92 or chipset specific method.

Typematic Rate Setting

This determines the typematic rate of the keyboard. The default value is "Disabled".

Enabled	Enable typematic rate and typematic delay programming
Disabled	Disable typematic rate and typematic delay programming. The system BIOS will use default value of these 2 items and the default is controlled by keyboard.

Typematic Rate (Chars/Sec)

This option refers to the number of characters the keyboard can type per second. The default value is "6".

6	6 characters per second
8	8 characters per second
10	10 characters per second
12	12 characters per second
15	15 characters per second
20	20 characters per second
24	24 characters per second
30	30 characters per second

Typematic Delay (Msec)

This option sets the display time interval from the first to the second character when holding a key. The default value is "250".

250	250 msec
500	500 msec
750	750 msec
1000	1000 msec

Security Option

This item allows you to limit access to the system and Setup, or just to Setup. The default value is "Setup".

System	The system will not boot and access to Setup will be denied if the incorrect password is entered at the prompt.
Setup	The system will boot, but access to Setup will be denied if the correct password is not entered at the prompt.

NOTE: *To disable security, select PASSWORD SETTING at Main Menu and then you will be asked to enter password. Do not type anything, just press <Enter> and it will disable security. Once the security is disabled, the system will boot and you can enter Setup freely.*

OS Select for DRAM >64MB

This segment is specifically created for OS/2 when DRAM is larger than 64MB. If your operating system is OS/2 and DRAM used is larger the 64MB, you have to select "OS 2", otherwise (under non-OS2), default is NON-OS2. The default value is "Non-OS2".

Report No FDD For Win 95

This option allows Windows 95 to share IRQ6 (assigned to a floppy disk drive) with other peripherals in case the drive does not exist. The default setting is "No".

A.3 Advanced Chipset Features

Since the features in this section are related to the chipset on the CPU board and are completely optimized, you are not recommended to change the default settings in this setup table unless you are well oriented with the chipset features.

**CMOS Setup Utility-Copyright © 1984-2001 Award Software
Advanced Chipset Features**

DRAM Timing	By SPD	Item Help
CASs Latency Time	2.5	Menu Level ►
Active to Recharge Delay	7	
DRAM RAS# to CAS# Delay	3	
DRAM RAS# Recharge	3	
DRAM Data Integrity Mode	Non-ECC	
MGM Core Frequency	Auto Max 400/333MHz	
System BIOS Cacheable	Enable	
Video BIOS Cacheable	Disabled	
Memory Hole At 15M-16M	Disabled	
Delayed Transaction	Disabled	
Delay Prior to Thermal	16 Min	
AGP Aperture Size (MB)	64	
Init Display First	Onboard	
** On-Chip VGA Setting **		
On-Chip VGA	Enabled	
On-Chip Frame Buffer Size	32MB	
Boot Display	Auto	
Panel Scaling	Auto	
Panel Number	640 x480	
↑↓→← : Move Enter: Select +/-/PU/PD: Value F10: Save ESC: Exit F1: General Help F5: Previous Values F6: Fail-Safe Defaults F7: Optimized Defaults		

SDRAM CAS latency Time

You can select CAS latency time in HCLKs 2, 3, or Auto. The board designer should set the values in this field, depending on the DRAM installed. Do not change the values in this field unless you change specifications of the installed DRAM or the installed CPU.

DRAM Data Integrity Mode

This option sets the data integrity mode of the DRAM installed in the system. The default setting is "Non-ECC".

System BIOS Cacheable

Selecting Enabled allows caching of the system BIOS ROM at F0000h-FFFFFh, resulting in better system performance. However, if any program writes to this memory area, a system error may result. The default value is "Disabled".

Video BIOS Cacheable

This item allows you to change the Video BIOS location from ROM to RAM. Video Shadow will increase the video speed.

Video RAM Cacheable

Selecting Enabled allows caching of the video BIOS ROM at C0000h to C7FFFh, resulting in better video performance. However, if any program writes to this memory area, a system error may result. The default value is "Disabled".

Memory Hole at 15M-16M

You can reserve this area of system memory for ISA adapter ROM. When this area is reserved, it cannot be cached. The user information of peripherals that need to use this area of system memory usually discusses their memory requirements. The default value is "Disabled".

Delayed Transaction

The chipset has an embedded 32-bit posted write buffer to support delay transactions cycles. Select *Enabled* to support compliance with PCI specification version 2.1. The options available are *Enabled* and *Disabled*.

AGP Aperture Size (MB)

The field sets aperture size of the graphics. The aperture is a portion of the PCI memory address range dedicated for graphics memory address space. Host cycles that hit the aperture range are forwarded to the AGP without any translation. The options available are 4M, 8M, 16M, 32M, 64M, 128M and 256M.

A.4 Integrated Peripherals

This option sets your hard disk configuration, mode and port.

**CMOS Setup Utility-Copyright © 1984-2001 Award Software
Integrated Peripherals**

▶ On Chip IDE Device	Press Enter	
▶ On Board Device	Press Enter	Menu Level ▶
▶ Superior Device	Press Enter	
Onboard LAN boot ROM	Disable	
↑↓→← : Move Enter: Select +/-/PU/PD: Value F10: Save ESC: Exit F1: General Help F5: Previous Values F6: Fail-Safe Defaults F7: Optimized Defaults		

**CMOS Setup Utility-Copyright © 1984-2001 Award Software
On Chip IDE Device**

IDE DMA transfer Access	Enabled	
On-Chip Primary PCI IDE	Enabled	Menu Level ▶
IDE Primary Master PIO	Auto	
IDE Primary Master PIO	Auto	
IDE Primary Master UDMA	Auto	
IDE Primary Master UDMA	Auto	
On-Chip Primary PCI IDE	Enabled	
IDE Secondary Master PIO	Auto	
IDE Secondary Master PIO	Auto	
IDE Secondary Master PIO	Auto	
IDE Secondary Master PIO	Auto	
** On-Chip Serial ATA Setting **		
SATA Mode	IDE	
On-Chip Serial ATA	Auto	
Serial ATA Port0	Primary Master	
Serial ATA Port1	Primary Master	
IDE HDD Block Mode	Enabled	

↑↓→← : Move Enter: Select +/-/PU/PD: Value F10: Save ESC: Exit F1:
 General Help
 F5: Previous Values F6: Fail-Safe Defaults F7: Optimized Defaults

**CMOS Setup Utility-Copyright © 1984-2001 Award Software
 On board Device**

USB Controller	Enable	
USB 2.0 Controller	Enabled	Menu Level ►
USB Keyboard Support	Disabled	
USB Mouse Support	Disabled	
AC97 Audio	Auto	
Hance Rapid Watchdog	0	

↑↓→← : Move Enter: Select +/-/PU/PD: Value F10: Save ESC: Exit F1:
 General Help
 F5: Previous Values F6: Fail-Safe Defaults F7: Optimized Defaults

**BIOS Setup Utility-Copyright © 1984-2001 Award Software
 Super IO Device**

Onboard FDC Controller	Enabled	
Onboard Serial Port 1	3F8/IRQ4	Menu Level ►
Onboard Serial Port 1	2F8/IRQ3	
UART Mode Select	Normal	
Red, TxD Active	Hi,Lo	
IR Transmission Delay	Enabled	
UR2 Duplex Mode	Half	
Use IR Pins	IR-Rx2Tx2	
Onboard Parallel Port	378/IRQ7	
Parallel Port Mode	SPP	
EPP Mode Select	EPP1.7	
ECP Mode Use DMA	3	
ICH Serial Port 1	3E8	
ICH Serial Port 1 Use IRQ	IRQ10	
ICH Serial Port 2	2E8	
ICH Serial Port 2 Use IRQ	IRQ11	
PWRON after power fail	OFF	

↑↓→← : Move Enter: Select +/-/PU/PD: Value F10: Save ESC: Exit F1:
 General Help
 F5: Previous Values F6: Fail-Safe Defaults F7: Optimized Defaults

IDE Primary/Secondary Master/Slave PIO

The four IDE PIO (Programmed Input/Output) fields let you set a PIO mode (0-4) for each of the four IDE devices that the onboard IDE interface supports. Modes 0 through 4 provide successively increased performance. In Auto mode, the system automatically determines the best mode for each device. The options available are Auto, Mode 0, Mode 1, Mode 2, Mode 3, and Mode 4.

IDE Primary/Secondary Master/Slave UDMA

Ultra DMA 66/100 implementation is possible only if your IDE hard drive supports it and the operating environment includes a DMA driver (Windows 95 OSR2 or a third-party IDE bus master driver). If your hard drive and your system software support Ultra DMA 33/66/100, select Auto to enable BIOS support. The options available are Auto, Mode 0, Mode 1, and Mode 2.

On-Chip Primary/Secondary PCI IDE

The integrated peripheral controller contains an IDE interface with support for two IDE channels. Select Enabled to activate each channel separately. The default value is "Enabled".

NOTE: *Choosing Disabled for these options will automatically remove the IDE Primary Master/Slave PIO and/or IDE Secondary Master/Slave PIO items on the menu.*

USB Keyboard Support

Select *Enabled* if your system contains a Universal Serial Bus (USB) controller and you have a USB keyboard.

Init Display First

This item allows you to decide to active whether PCI Slot or AGP first. The options available are PCI Slot, AGP.

IDE HDD Block Mode

This field allows your hard disk controller to use the fast block mode to transfer data to and from your hard disk drive.

POWER ON Function

This option allows users to select the type of power ON sequence for the system to follow. The default value is "Button-Only".

BUTTON-ONLY	Follows the conventional way of turning OFF system power (via power button).
Password	Upon selecting this option, the KB POWER ON Password line appears. Press <Enter> and you'll be prompted to enter and confirm a password of your choice. After setting the password, succeeding attempts to power ON the system will result to null. For system to activate, user must input the password via keyboard then press <Enter>.
Hot KEY	This option is very similar with that of Password. Hot-key combinations range from Ctrl-F1 to Ctrl-F12. User may define this combination from the Hot key Power ON option.

Onboard FDC Controller

Select Enabled if your system has a floppy disk controller (FDC) installed on the system board and you wish to use it. If you install and-in FDC or the system has no floppy drive, select Disabled in this field. The options available are Enabled, Disabled.

Onboard Serial Port 1/Port 2

Select an address and corresponding interrupt for the first and second serial ports. The options available are 3F8/IRQ4, 2E8/IRQ3, 3E8/IRQ4, 2F8/IRQ3, Disabled, Auto.

UART2 Duplex Mode

The second serial port offers these infrared interface modes:

- ✓ IrDA
- ✓ ASKIR IrDA-compliant serial infrared port
- ✓ Normal (default value)

NOTE: *The UART Mode Select will not appear on the menu once you disable the setting of Onboard Serial Port 2.*

When UART Mode Select is set as ASKIR or IrDA, the options RxD, TxD Active and IR Transmission delay will appear.

Parallel Port Mode

Select an operating mode for the onboard parallel (printer) port. Select Normal unless your hardware and software require one of the other modes offered in this field. The options available are EPP1.9, ECP, SPP, ECPEPP1.7, and EPP1.7.

ECP Mode Use DMA

Select a DMA channel for the parallel port for use during ECP mode.

ACPI Function

This item allows you to enable/disable the Advanced Configuration and Power Management (ACPI). The options available are Enabled, Disabled.

Power Management

This option allows you to select the type (or degree) of power saving for Doze, Standby, and Suspend modes. The table below describes each power management mode:

Max Saving	Maximum power savings. Only Available for SL CPUs. Inactivity period is 1 minute in each mode.
User Define	Sets each mode individually. Select time-out periods in the PM Timers section, following.
Min Saving	Minimum power savings. Inactivity period is 1 hour in each mode (except the hard drive).
Disabled	Default value

PM Control by APM

If Advanced Power Management (APM) is installed on your system, selecting Yes gives better power savings. The default value is "Yes".

No	System BIOS will ignore APM when power managing the system
Yes	System BIOS will wait for APM's prompt before it enters any PM mode (i.e., DOZE, STANDBY or SUSPEND). Note: If APM is installed or if there is a task running, even when the timer has timed out, the APM will not prompt the BIOS to put the system into any power saving mode!

NOTE: *If APM is not installed, this option has no effect.*

Video Off Method

Determines the manner in which the monitor is blanked.

V/H SYNC+Blank	Turns OFF vertical and horizontal synchronization ports and writes blanks to the video buffer
DPMS	Select this option if your monitor supports the Display Power Management Signaling (DPMS) standard of the Video Electronics Standards Association (VESA). Use the software supplied for your video subsystem to select video power management values.
Blank Screen	System only writes blanks to the video buffer.

Video Off After

As the system moves from lesser to greater power-saving modes, select the mode in which you want the monitor to blank off. The default value is "Standby".

NA	System BIOS will never turn off the screen
Suspend	Screen off when system is in SUSPEND mode
Standby	Screen off when system is in STANDBY mode
Doze	Screen off when system is in DOZE mode

NOTE: Green monitors detect the V/H SYNC signals to turn off its electron gun

Modem Use IRQ

3, 4, 5, 7, 9, 10, 11, NA	For external modem, 3 or 4 will be used for card type modem. It is up to card definition. Default is 3.
---------------------------	---

Doze Mode

After the selected period of system inactivity (1 minute to 1 hour), the CPU clock runs at slower speed while all other devices still operate at full speed. The default value is "Disabled".

Disabled	System will never enter doze mode
1/2/4/6/8/10/20/30/40 Min/1 Hr	Defines the continuous idle time before the system entering DOZE mode.

Standby Mode

After the selected period of system inactivity (1 minute to 1 hour), the fixed disk drive and the video shut off while all other devices still operate at full speed. The default value is "Disabled".

Disabled	System will never enter STANDBY mode
1/2/4/6/8/10/20/30/40 Min/1 Hr	Defines the continuous idle time before the system entering STANDBY mode. If any item defined in (J) is enabled & active, STANDBY timer will be reloaded

Suspend Mode

After the selected period of system inactivity (1 minute to 1 hour), all devices except the CPU shut off. The default value is "Disabled".

Disabled	System will never enter SUSPEND mode
----------	--------------------------------------

1/2/4/6/8/10/20/ 30/40 Min/1 Hr	Defines the continuous idle time before the system entering SUSPEND mode. If any item defined in (J) is enabled & active, SUSPEND timer will be reloaded
------------------------------------	---

HDD Power Down

After the selected period of drive inactivity (1 to 15 minutes), the hard disk drive powers down while all other devices remain active. The default value is "Disabled".

Disabled	HDD's motor will not power OFF.
1/2/3/4/5/6/7/8/ 9/10/11/12/13/1 4/15 Min	Defines the continuous HDD idle time before the HDD enters power saving mode (motor OFF)

Throttle Duty Cycle

When the system enters Doze mode, the CPU clock runs only part of the time. You may select the percent of time that the clock runs. The default value is "62.5%".

VGA Active Monitor

When Enabled, any video activity restarts the global timer for Standby mode. The default value is "Enabled".

Soft-Off by PWR-BTTN

This option only works with systems using an ATX power supply. It also allows the user to define which type of soft power OFF sequence the system will follow. The default value is "Instant-Off".

Instant-Off	This option follows the conventional manner systems perform when power is turned OFF. Instant-Off is a soft power OFF sequence requiring only the switching of the power supply button to OFF
Delay 4 Sec.	Upon turning OFF system from the power switch, this option will delay the complete system power OFF sequence by approximately 4 seconds. Within this delay period, system will temporarily enter into Suspend Mode enabling you to restart the system at once.

Power On by Ring

This option allows the system to resume or wake up upon detecting any ring signals coming from an installed modem. The default value is "Enabled".

IRQ 8 Break Suspend

You can turn on or off monitoring of IRQ8 (the Real Time Clock) so it

does not awaken the system from Suspend mode. The default value is "Disabled".

Reload Global Timer Events

When *Enabled*, an event occurring on each device listed below restarts the global time for Standby mode.

Resources Controlled By

The Award Plug and Play BIOS can automatically configure all the boot and Plug and Play-compatible devices. If you select Auto, all the interrupt request (IRQ), DMA assignment, and Used DMA fields disappear, as the BIOS automatically assigns them. The default value is "Manual".

IRQ Resources

When resources are controlled manually, assign each system interrupt as one of the following types, depending on the type of device using the interrupt:

1. Legacy ISA Devices compliant with the original PC AT bus specification, requiring a specific interrupt (such as IRQ4 for serial port 1).
2. PCI/ISA PnP Devices compliant with the Plug and Play standard, whether designed for PCI or ISA bus architecture.

The default value is "PCI/ISA PnP".

DMA Resources

When resources are controlled manually, assign each system DMA channel as one of the following types, depending on the type of device using the interrupt:

1. Legacy ISA Devices compliant with the original PC AT bus specification, requiring a specific DMA channel.
2. PCI/ISA PnP Devices compliant with the Plug and Play standard, whether designed for PCI or ISA bus architecture.

The default value is "PCI/ISA PnP".

Memory Resources

This sub menu can let you control the memory resource.

PCI/VGA Palette Snoop

Some non-standard VGA display cards may not show colors properly. This field allows you to set whether MPEG ISA/VESA VGA Cards can work with PCI/VGA or not. When enabled, a PCI/VGA can work with a MPEG ISA/VESA VGA card. When disabled, a PCI/VGA cannot work with a MPEG ISA/VESA Card.

Assign IRQ For USB/VGA

Enable/Disable to assign IRQ for USB/VGA.

A.10 Load Optimized Defaults

This option allows you to load the default values to your system configuration. These default settings are optimal and enable all high performance features.

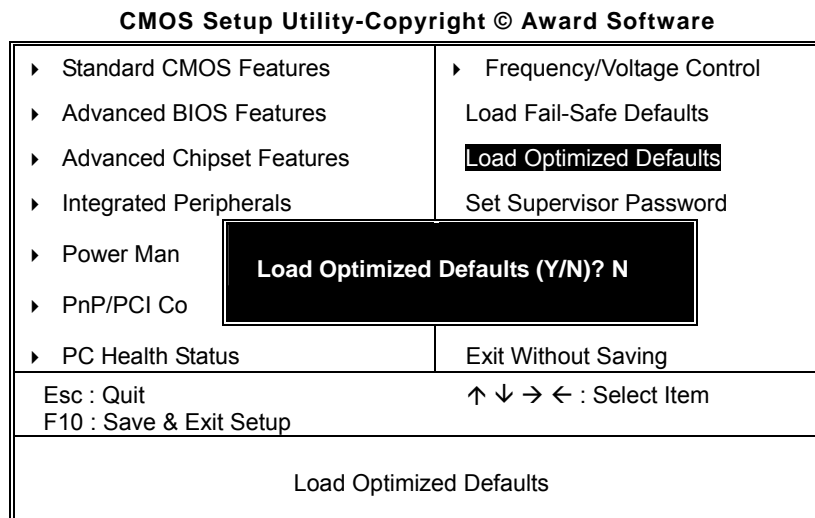

To load SETUP defaults value to CMOS SRAM, enter "Y". If not, enter "N".

Appendix B

Power Supply Specification

Power Supply: FSP180-50PLA1 (180W, AC 110~230V Input)

ELECTRICAL REQUIREMENTS

OUTPUT ELECTRICAL REQUIREMENTS

The subject power supply will meet all electrical specifications below, over the full operation temperature range and dynamic load regulation.

OUTPUT RATING

Output	Nominal	Regulation	Ripple/Noise	Min	Max
1	+3.3V	±5%	50mV	0.3A	10.0A
2	+5V	±5%	50mV	0.3A	16.0 A
3	+12V	±5%	120mV	1.5A	14.0 A
4	-12V	±10%	120mV	0.0 A	0.3A
5	+5VSB	±5%	50mV	0.0 A	2.0A

※ -12V,+3.3V, +5V,+12V will have the regulation to ±10% when all load take off.

The +3.3V and +5V total output shall not exceed 61watts. The +3.3V, +5V,and +12V total output shall not exceed 165watts and the total output for this subject power supply is 180 watts. Ripple and noise measurements shall be made under all specified load conditions through a single pole low pass filter with 20MHz cutoff frequency. Outputs shall bypassed at the connector with a 0.1uF ceramic disk capacitor and a 10uF electrolytic capacitor to simulate system loading.

LOAD CAPACITY SPECIFICATIONS

The cross regulation defined as follows, the voltage regulation limits DC include DC Output ripple & noise.

LOAD	STM	+3.3V	+5V	+12V	-12V
ALL MAX	HHHH	4.5A	9.0A	9.0A	0.8A
+5V MAX other MIN	LHLL	0.3A	12.0 A	1.5A	0.0A
+3.3V MAX other MIN	HLLL	16.8 A	0.3 A	1.5A	0.0A
+12V MAX other MIN	LLHL	0.3 A	0.3 A	10.0A	0.0A
ALL MIN	LLLL	0.3 A	0.3 A	1.5A	0.0A

HOLD-UP TIME (@FULL LOAD)

115V / 60Hz : 17 mSec. Minimum.

230V / 50Hz : 17 mSec. Minimum.

OUTPUT RISE TIME

(10% TO 90% OF FINAL OUTPUT VALUE, @FULL LOAD)

115V-rms or 230V-rms + 5Vdc : 20ms Maximum

OVER VOLTAGE PROTECTION

+5V_{dc} output: +5.7V_{dc} minimum, + 6.5V_{dc} maximum

+12V_{dc} output: +13.3V_{dc} minimum, +15.6V_{dc} maximum

+ 3.3V_{dc} output: +3.7V_{dc} minimum, + 4.5V_{dc} maximum

SHORT CIRCUIT PROTECTION

Output short circuit is defined to be a short circuit load of less than 0.1 ohm.

In the event of an output short circuit condition on +3.3V, +5V or +12V output, the power supply

will shutdown and latch off. The power supply shall return to normal operation after the short

circuit has been removed and the power switch has been turned off for no more than 2 seconds.

In the event of an output short circuit condition –12V output, the power supply will not be latch off.

The power supply shall return to normal operation as soon as the short circuit has been removed and

the power switch has been turned off for no more than 2 seconds.

OVERLOAD PROTECTION

Overload currents defined as a 10 amp/sec fault current ramp starting from full load, applied to the

+3.3V, +5V output, shall not cause that output to exceed 32 amps before the output voltage drops

below 0.5 volts and is latched off. The +12V output shall not exceed 20 amps under the same ramp

conditions starting at full load before it is latched off.

POWER GOOD SIGNAL

The power good signal is a TTL compatible signal for the purpose of initiating an orderly star-up

procedure under normal input operating conditions. This signal is asserted (low) until +5Vdc has

reached 4.75 volts during power up. Characteristics:

TTL signal asserted (low state) : less than 0.5V while sinking 10mA.

TTL signal asserted (high state): greater than 4.75V while sourcing 500uA.

High state output impedance: less or equal to 1Kohm from output to common.

POWER GOOD @ 115/230V, FULL LOAD	100 –500mSec.
POWER FAIL @115/230V, FULL LOAD	1 mSec. minimum

EFFICIENCY

115 VAC @Full Load	68% minimum
230 VAC @Full Load	68% minimum

ENVIRONMENTAL REQUIREMENTS

The power supply will be compliant with each item in this specification for the following Environmental conditions.

TEMPERATURE RANGE

Operating	0 to +50 deg. C
Storage	-20 to +80 deg. C

HUMIDITY

Operating	5 –95% RH, Non-condensing
Storage	5 –95% RH, Non-condensing

VIBRATION

The subject power supplies will withstand the following imposed conditions without experiencing

non-recoverable failure or deviation from specified output characteristics.

Vibration Operating – Sine wave excited, 0.5 G maximum acceleration, 10-250 Hz swept at one

octave / min. Fifteen minute dwell at all resonant points, where resonance is defined as those

exciting frequencies at which the device under test experiences excursions two times large than

non-resonant excursions.

Plane of vibration to be along three mutually perpendicular axes.

SHOCK

The subject power supplies will withstand the following imposed conditions without experiencing non-recoverable failure or deviation from specified output characteristics.

Storage -40G, 11 mSec. half-sine wave pulse in both directions on three mutually perpendicular axes.

Operating -10G, 11mSec. half-sine wave pulse in both directions on three mutually Perpendicular axes.